

# STRIKER™ SERIES



## STRIKER-2

### HIGH PRESSURE 2-STAGE FIRE PUMP

The **WATERAX STRIKER-2** also known as STRIKER-II Plus® pump, pairs a reliable 2-stage pump end with the **Honda 4-stroke 13 HP** engine to achieve pressures of up to **230 PSI (15.9 BAR)** and flow rates reaching **105 GPM (397 L/Min)**. It can be used by itself, in tandem or in parallel with other **WATERAX** pumps, and is also a very popular choice for slip-on applications.

The **WATERAX** quick release clamp provided on the **STRIKER-2** pump lets you replace a damaged pump end in the field with minimal equipment downtime. This interchangeability greatly reduces your spare parts inventory and improves your ability to respond to unforeseen equipment damage. The **Honda 4-stroke 13 HP** engine makes for ease of operation and engine parts sourcing.

**Emissions compliant; engine is CARB and EPA certified**

#### Applications

- Firefighting operations using higher flows
- Accuracy in flow trajectory when structure fire fighting
- Tandem pumping over long distances
- Parallel pumping for higher volumes
- Slip-on units

#### Features and Benefits

- Quick release clamp and swappable pump ends for minimal equipment downtime and inventory
- Sealed bearing to eliminate pump end greasing in the field
- Belt drive system for reliable, low maintenance performance
- Aluminium alloy pump components and anodized parts for lighter weight and greater resistance to corrosion
- Comprehensive user and service manuals

## SPECIFICATIONS

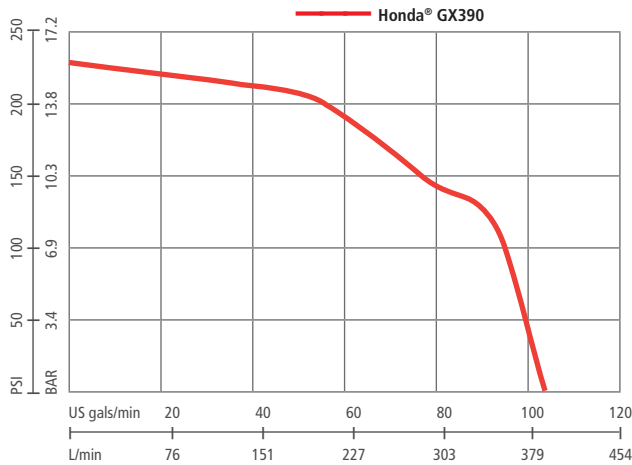

### Flow rate at specified pressure

Maximum Pressure: 230 PSI (15.9 bar)  
 Free flow: 105 US gals/min (397 L/min)  
 Maximum Head: 531' (162 m)

Flow Rate		Pressure		
US GPM	(LPM)	@	PSI	(BAR)
97	(367)	@	100	(6.9)
80	(303)	@	150	(10.3)
58	(220)	@	250	(13.8)

Engine: Honda® GX390

### Engine Specifications

<b>Model &amp; Type</b>	Honda, GX390 Series 4-cycle, horizontal shaft, single cylinder, OHV
<b>Net Power</b>	11.7 HP (8.7 kW) @ 3600 RPM
<b>Net Torque</b>	19.5 lb-ft (26.4 Nm) @ 2500 RPM
<b>Bore &amp; Stroke</b>	3.46 x 2.52 inches (88 x 64 mm)
<b>Displacement</b>	23.74 cubic inches (389 cc)
<b>Starting System</b>	12 VDC electric with manual recoil backup start
<b>Ignition</b>	Digital CDI with variable ignition timing
<b>Charging</b>	3 AMP regulating alternator
<b>Wiring</b>	Pre-wired for Fast Wire panel connections (panels purchased separately).
<b>Governor</b>	Centrifugal Mass Type
<b>Cooling</b>	Air Cooled
<b>Lubrication</b>	Oil, Splash
<b>Oil Capacity</b>	1.16 quarts (1.1 liters)
<b>Fuel Pump</b>	18 inch lift.
<b>Emissions</b>	Meets current CARB, EPA, and CE requirements.
<b>Fuel Type</b>	Gasoline [unleaded, 86 minimum octane, 10% maximum ethanol]
<b>Fuel Tank</b>	6.4 quarts (6.1 liters)
<b>Fuel Consumption</b>	0.92 US gals/hr (6.8 liters/hr)
<b>Muffler</b>	Forestry approved spark arrestor

### Pump Specifications

<b>Type</b>	Detachable 2-stage Centrifugal
<b>Ratings</b>	ISO 9 (Texas Only) and NFPA 1906 Medium Pressure Rating of 50 GPM
<b>Description</b>	Medium Pressure, Low Flow, Foam Compatible
<b>Maximum Allowable Pressure</b>	600 PSI (41.4 bar)
<b>Intake</b>	2" Male NPSH Thread (other connections available)
<b>Discharge</b>	Check Valve: 1-1/2" male NPSH thread (meets US Forest Service Specification 5100-382)
<b>Body &amp; Diffusers</b>	Anodized corrosive resistant aluminum
<b>Impellers</b>	3.67" Diameter; Anodized corrosive resistant aluminum
<b>Pump Shaft</b>	Stainless Steel
<b>Bearings</b>	Maintenance Free; sealed ball bearing and sintered bronze sleeve
<b>Pump Seal</b>	Maintenance Free; Blister-resistant carbon seal face, silicon carbide seat, and fully integrated drive bushing.
<b>Clamp</b>	Hand tight quick release clamp [no tools needed]
<b>Drive Unit</b>	Timing Belt and Pulley; Speed Increaser
<b>Speed Increaser Position</b>	Vertical
<b>Drive Ratio</b>	1.88: 1
<b>Color</b>	Red
<b>Special Feature</b>	The entire pump separates completely from the engine/speed increaser.

All features are not available on every model. Please refer to the product selection matrix to select the proper model.

## SPECIFICATIONS

### STR2-13V

#### Primer Specifications

<b>Hand Primer Option</b>	Guzzler, Diaphragm Type; Reliable, Lightweight and Rugged
<b>Intake and Discharge Port Size</b>	½" Female NPT
<b>Construction:</b>	Aluminum Handle, composite body, buna-n reinforced diaphragm and flapper valves
<b>Lift</b>	12 feet (3.7 m) [up to approximately 16 feet (4.8 m) with suction hose footvalve]
<b>Head Capacity</b>	30 ft (9.1 m)
<b>Maximum Pressure</b>	15 PSI (1.03 bar)
<b>Maximum Service Temp</b>	150° F (66° C)
<b>Volume per Stroke</b>	0.44 quart (0.42 liter)
<b>Dimensions (L x W x H)</b>	12-3/4" x 4-1/2" x 4-5/16" (324 x 114 x 110 mm)
<b>Weight</b>	1.70 lbs (0.77 kg)

Shipped loose with connection hardware and 6 feet of hose

<b>Electric Primer Option</b>	12 VDC Piston Type Vacuum Pump
<b>Intake and Discharge Port Size</b>	3/8" Female NPT
<b>Construction</b>	Corrosion Resistant Aluminum with Bronze Sleeve and Composite Piston
<b>Max. Current Draw</b>	105 amps
<b>Lift</b>	25 feet (7.6 m)
<b>Vacuum</b>	22 in-Hg
<b>Dimensions</b>	9" x 4-1/8" x 7-1/2" (229 x 105 x 191 mm)
<b>Weight</b>	8.1 lbs (3.7 kg)
<b>Vehicle Units</b>	Shipped loose with mounting plate, hardware, and 6 feet of hose

#### Unit Base Specifications

<b>Vehicle Mount</b>	Black flat base with tubular horizontal legs. (Provided with industrial grade stud isolators - shipped loose)
----------------------	------------------------------------------------------------------------------------------------------------------

#### Control Panel Options

<b>Engine supplied controls</b>	Push/Pull choke, venier throttle, push start, and toggle On/Off Switch. (Note: Fuel valve lever on the engine itself not on panels)
<b>FastWire quick connect</b>	Loomed engine wire harness (pre-wired to engine) with 8 pin Molex MX150L Industrial Sealed Male Connector. All Vehicle Mounted BB-4 pumps are equipped with FastWire quick connect engine wire harness for plug & play ease in connecting pump engine, power, and control components such as the WATERAX Control Panels MCP, PMSCP, WCP* Series.
<b>WATERAX Control Panels</b>	MCP, PMSCP, WCP* Series *Water and/or foam level monitors, electric primer, work light options available.

Note: Refer to the *WATERAX* Control Panel data sheet and specifications to select a remote mount panel and/or call your *WATERAX* dealer to customize your own control panel with water and/or foam level monitors, and toggle switches for optional electric primer and work light.

**SPECIFICATIONS****STR2-13P****Primer Specifications****Utility Hand Pump**

<b>Discharge Port Size</b>	½" Hose Barb
<b>Construction</b>	Brass cylinder with neoprene seals and caps.
<b>Maximum operating temperature</b>	140°F (60°C)
<b>Volume per Stroke</b>	26 full strokes per gallon
<b>Dimensions (L x W)</b>	1-1/4" Diameter x 12 inches long
<b>Weight</b>	2 lbs (.91 kg)

Clipped to pump increaser housing.

**Unit Base Specifications**

Black flat base with four tubular handles as an integral part of the base.

**Controls**

Engine choke, throttle, and fuel valve control levers; keyed start switch; and low oil pressure alert lamp and shutdown.

**PRODUCT SELECTION**

**PRODUCT SELECTION MATRIX**

			STR2-13P	STR2-13V
STANDARD INCLUSIONS	Primer	Jabsco Hand Primer	S	-
		Guzzler Hand Primer	-	O
		Electric Primer	-	O
	Muffler	Forestry Approved Spark Arrestor	S	S
	Drive Orientation	Vertical	S	S
		Horizontal	-	-
	Controls	Engine Controls	S	O
		WATERAX Control Panels	-	O
	Dimensions	L x W x H	30.5" x 21.5" x 20.8"	30.5" x 21.5" x 20.8"
Weight		127 lbs (58 kg)	127 lbs (58 kg)	

Standard **S** Option **O** Not applicable **-**

**OPTIONS & ACCESSORIES**

**Sold Separately**

**CONTROLS**



**PMSCP**

Panel Mount Standard Control Panel  
w/ FastWire CTRL connector.



**MCP**

Mini Control Panel  
w/ FastWire CTRL connector.



**WCP**

WATERAX Control Panel  
w/ FastWire PWR & CTRL connectors.

**ELECTRIC KIT**



**BATKIT-66**

Deep Cycle Battery Kit  
w/ FWP-9 cable



**WLIGHTKIT**

LED Work Light w/ 5'  
harness & toggle switch



**FWX-3**

3' CTRL Cable Extension  
w/ two 8 pin connectors



**FWP-20**

20' PWR Cable with lugs  
& Anderson conn.

**FWP-9**

9' PWR Cable w/ lugs  
& Anderson conn.

**FWP-3**

3' PWR Cable w/ lugs  
& Anderson conn.

**PRIMER**



**GZPRIMERKIT**

Guzzler Hand Primer  
with hose & valve



**EPRIMERKIT**

Electric Primer w/ plate,  
5' harness & switch



- ADP-A-FM20S**
- ADP-A-FM20SP**
- ADP-A-FM20SV**
- ADP-A-FM15SN**
- ADP-A-FM15S**
- ADP-A-FM15SP**
- ADP-A-FM15SV**

- ADAPTER 2" NPSH FEMALE TO NPSH MALE
- ADAPTER 2" NPSH FEMALE TO NPT MALE
- ADAPTER 2" NPSH FEMALE TO VICTAULIC
- ADAPTER 1-1/2" NPSH FEMALE TO NH MALE
- ADAPTER 1-1/2" NPSH FEMALE TO NPSH MALE
- ADAPTER 1-1/2" NPSH FEMALE TO NPT MALE
- ADAPTER 1-1/2" NPSH FEMALE TO VICTAULIC



**B-6365**

CHECK VALVE MANIFOLD 1-1/2 NPSH

**PUMP INTAKE & DISCHARGE ADAPTER**

**TECHNICAL DRAWINGS**

**STR2-13P** Length 33" (83.8 cm) Width 18-1/4" (46.3 cm) Height 20-1/2" (52 cm) Weight 127 lbs (58 kg)

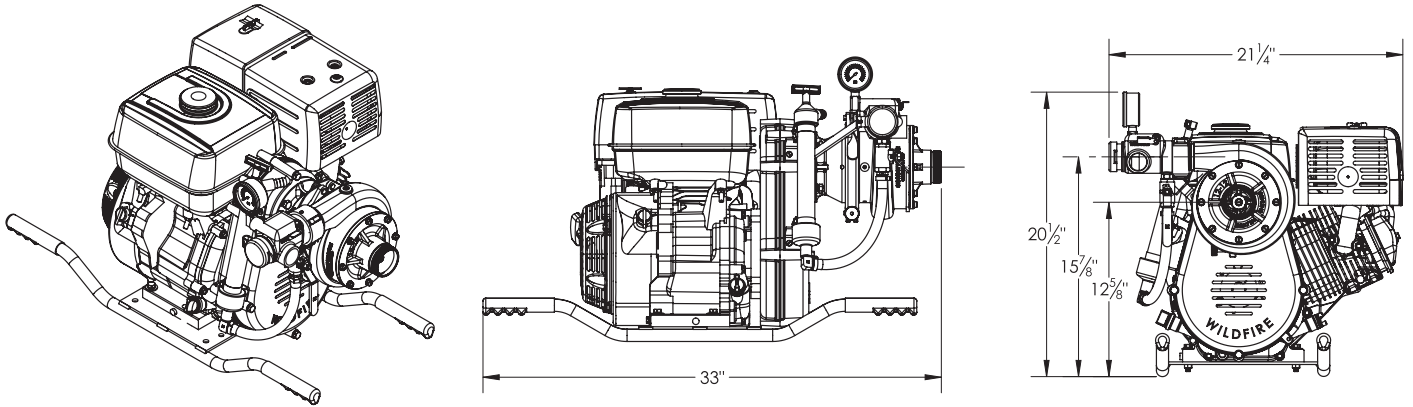

**STR2-13V** Length 26.02" (66 cm) Width 18.25" (46.6 cm) Height 19.88" (50.5 cm) Weight 127 lbs (58 kg)

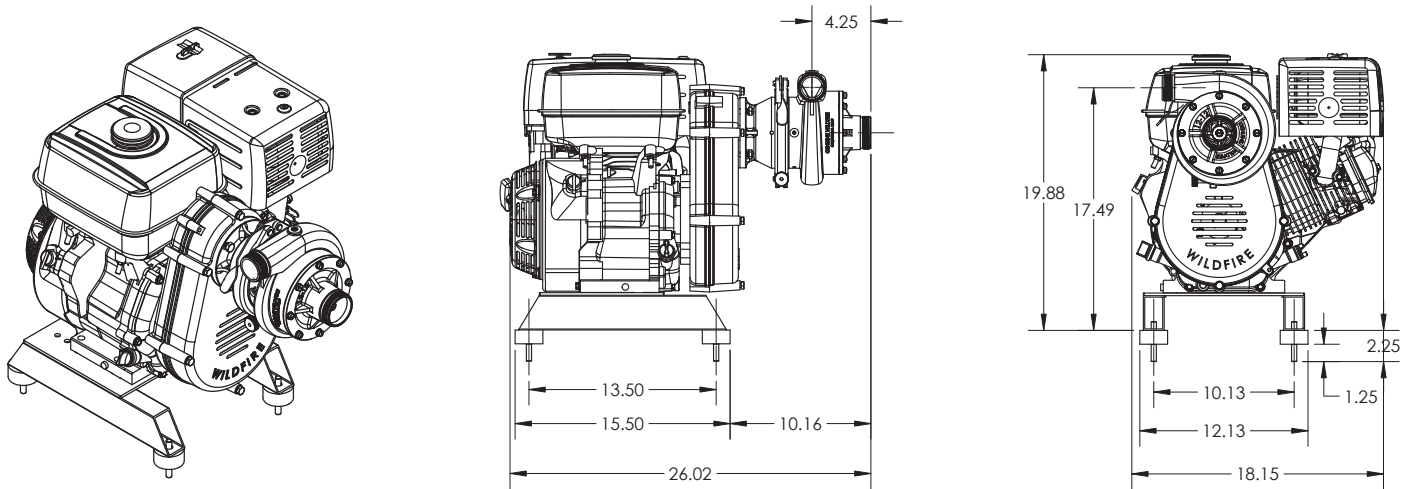



**WATERAX Inc.**  
6635 Henri-Bourassa W.  
Montreal, QC H4R 1E1

**TF 855-616-1818**

**T** 514-637-1818

**F** 514-637-3985

info@waterax.com  
www.waterax.com

Distributed by:

All information contained in this document including drawings is proprietary to *WATERAX* and may not be copied, reproduced or used in whole or in part without our prior written permission. The information in this document is subject to change without notice. Model displayed with multiple options. Weight and dimensions are approximated and may vary depending on options.